

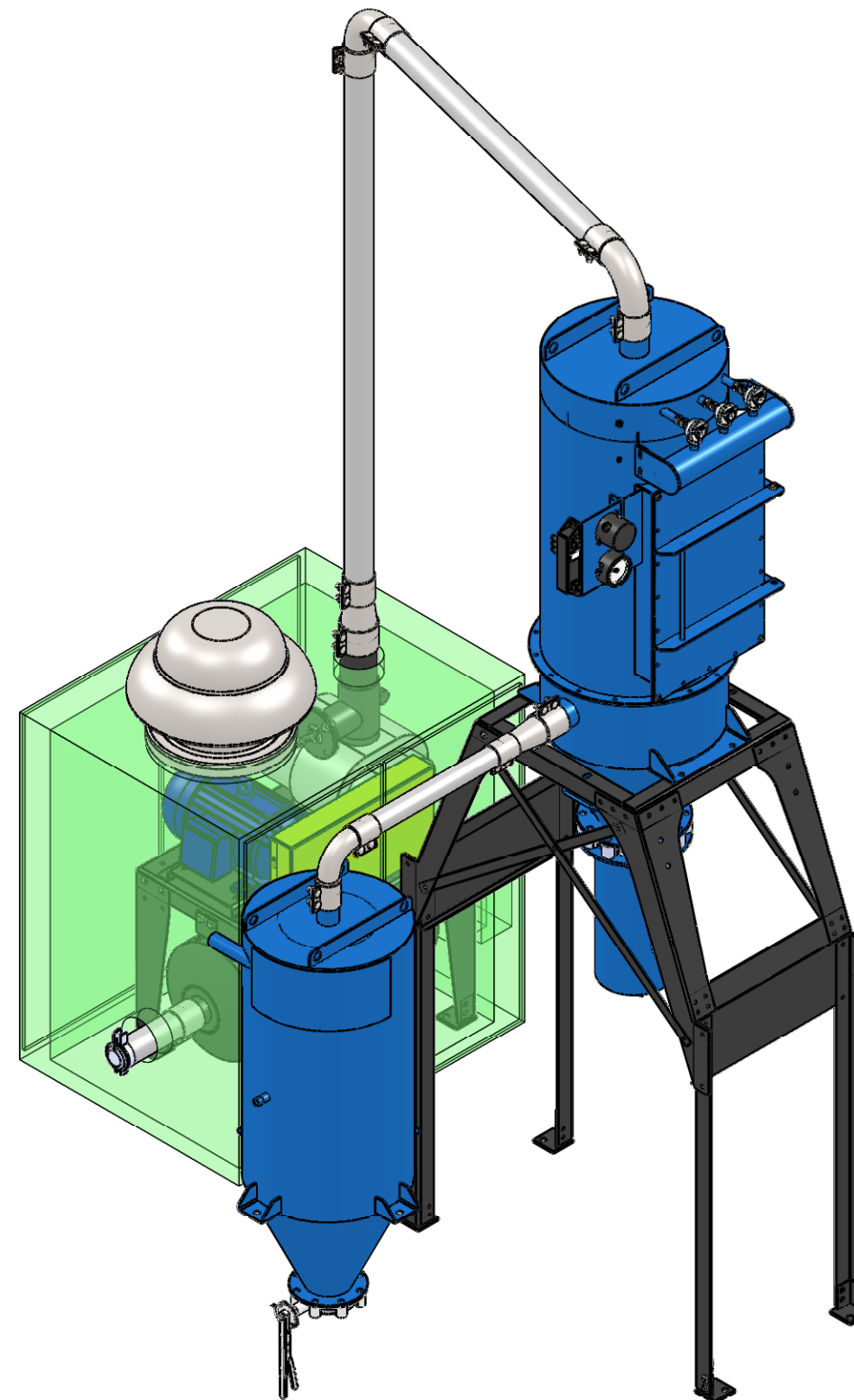

AMERICAN VACUUM COMPANY
 7301 N MONTICELLO AVE
 SKOKIE, IL 60076
 800-321-2849

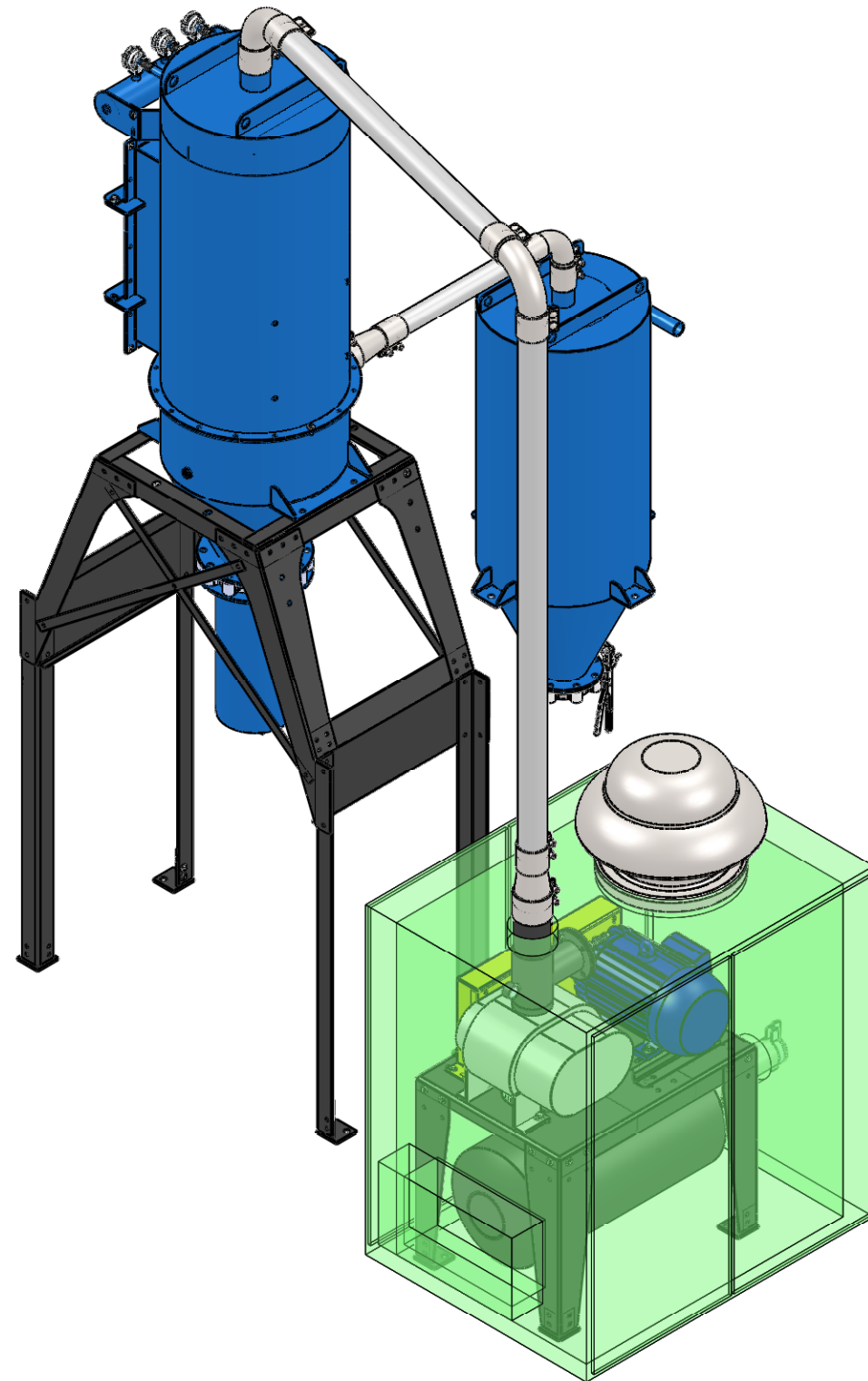

GENERAL SPECIFICATIONS:

1. 400 ICFM @ 16" Hg. CONTINUOUS
2. SUTORBIT 6M VACUUM PRODUCER WITH 20hp TEFC 1800 RPM 460/3/60 MOTOR
3. 90 SFt FILTER, POLYESTER FELT WITH 99.9% @ 0.5 MICRONS, STANDARD
4. EFFECTIVE FILTER CLEANING VIA PULSE-JET
5. MOUNTED ON HEAVY-DUTY STEEL STRUCTURE
6. NOISE : 85 dBA @ 3 ft (1m)
7. WEIGHT ~ 2100 lbs

PAINT SPEC:
 EQUIPMENT COLOUR - DUROVAC BLUE
 STRUCTURAL FRAME COLOUR - BLACK

Note - All dimensions are in Inches

CUSTOMER:

*

PROJECT:

05369

TITLE: CVS Components 20Hp, 6M with 26" Dia Filter Separator & 24" Dia Primary Separator

SHEET SIZE:

B

SCALE:

1:24

THE INFORMATION CONTAINED IN THIS DRAWING IS PROPRIETARY. NO PART OF THIS DRAWING MAY BE TRANSMITTED TO OTHER PARTIES WITHOUT PRIOR WRITTEN PERMISSION FROM NORTHWIND AIR SYSTEMS OR ITS APPROVED AGENTS.

SHEET 1 OF 2

DRAWN BY:

RAVI

DATE:

2012/09/04

CHECKED BY:

KRW

DATE:

2012/09/04

DWG NO:

05369-A001

REV. NO:

B



AMERICAN VACUUM COMPANY
 7301 N MONTICELLO AVE
 SKOKIE, IL 60076
 800-321-2849

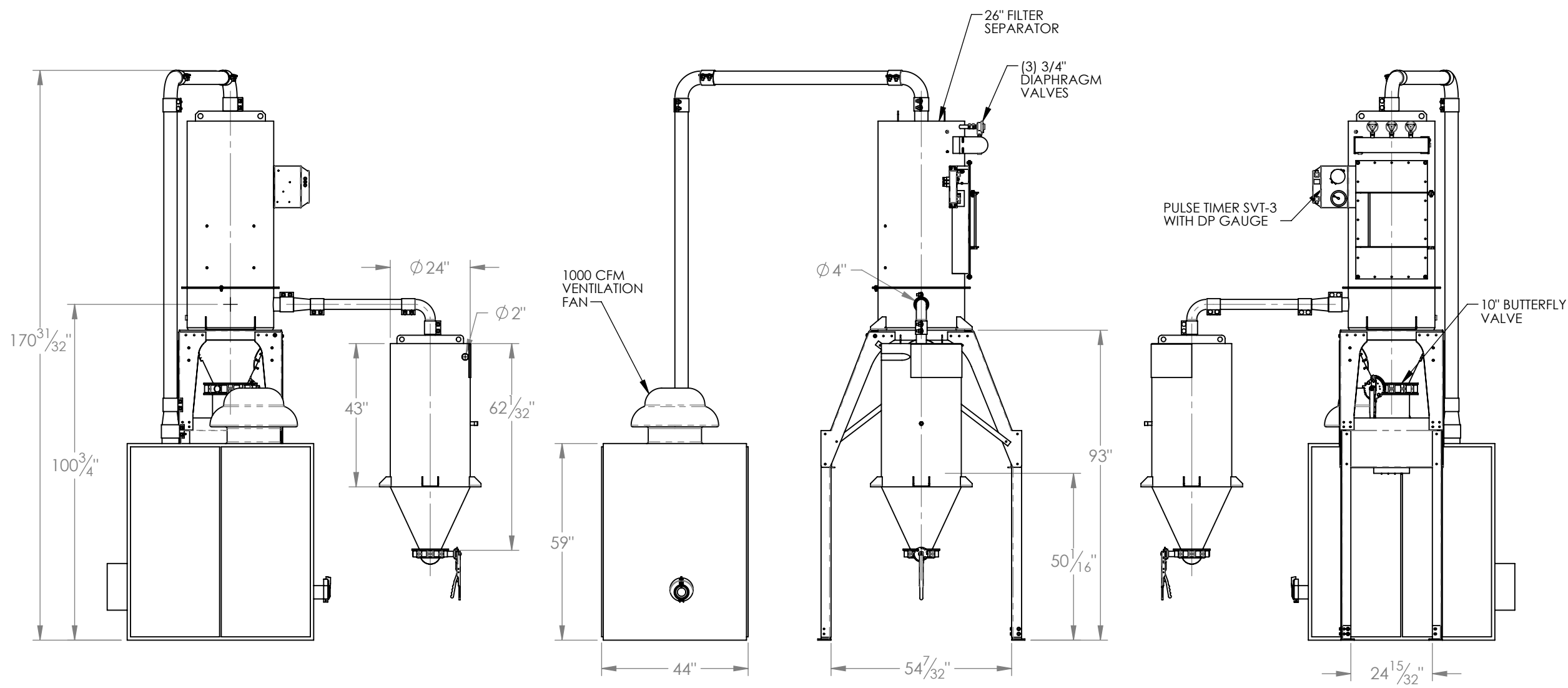
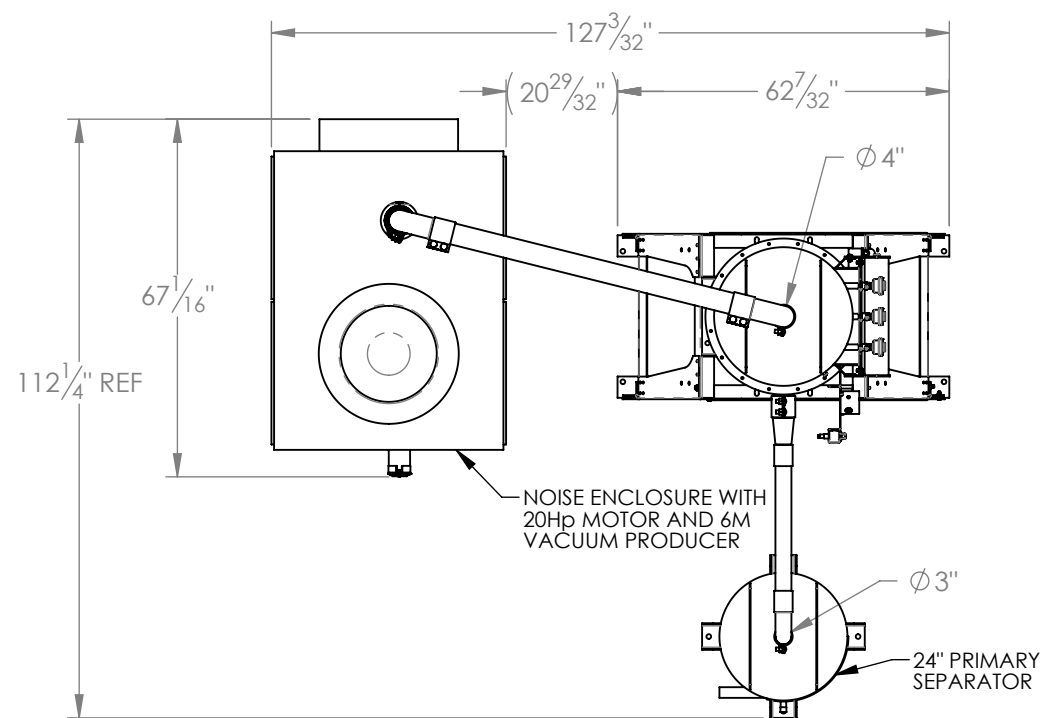

CUSTOMER:		*	
PROJECT:		05369	
TITLE: CVS Components 20Hp, 6M with 26" Dia Filter Separator & 24" Dia Primary Separator			
SHEET SIZE:	SCALE:	THE INFORMATION CONTAINED IN THIS DRAWING IS PROPRIETARY. NO PART OF THIS DRAWING MAY BE TRANSMITTED TO OTHER PARTIES WITHOUT PRIOR WRITTEN PERMISSION FROM NORTHWIND AIR SYSTEMS OR ITS APPROVED AGENTS.	
B	1:36		
SHEET 2 OF 2			
DRAWN BY:		DATE:	
RAVI		2012/09/04	
CHECKED BY:		DATE:	
KRW		2012/09/04	
DWG NO: 05369-A001			REV. NO: B